



*An Online PDH Course
brought to you by
CEDengineering.com*

An Introduction to Electrical Safety: *Underground and Low Voltage Interior*

Course No: E02-016

Credit: 2 PDH

J. Paul Guyer, P.E., R.A., Fellow ASCE, Fellow AEI



Continuing Education and Development, Inc.

P: (877) 322-5800

info@cedengineering.com

www.cedengineering.com

This course was adapted from the Unified Facilities Criteria of the United States government, which is in the public domain.

CONTENTS

- 1. UNDERGROUND WORK**
- 2. GENERAL PROTECTION REQUIREMENTS**
- 3. CABLE PULLING**
- 4. BURIED ELECTRICAL CABLES**
- 5. DAMAGE TO EXISTING UTILITY LINES**
- 6. PREPARING TO WORK UNDERGROUND**
- 7. WORK INSIDE UNDERGROUND STRUCTURES**
- 8. LOW VOLTAGE INTERIOR SYSTEMS**

1. UNDERGROUND WORK.

1.1 THIS PUBLICATION applies to work in manholes, vaults, and handholes; work on duct lines, trenches, and underground cables; and work on ground-mounted and underground equipment associated with underground electrical lines. In addition to the criteria provided below, comply with OSHA 29 CFR 1910.146, Permit-Required Confined Spaces.

1.2 TREAT UNDERGROUND STRUCTURES such as manholes and unvented vaults as confined spaces.

1.3 ALL EQUIPMENT inside an underground structure (including manholes and vaults) operating at high voltage levels should be deenergized before allowing entry into the underground structure. This includes insulated conductors. If the equipment inside the manhole cannot be deenergized, apply the personal protective equipment requirements of Tables 4-1 and 4-2. If a cable in an underground structure has one or more abnormalities that could lead to or be an indication of an impending fault, the defective cable must be deenergized before any employee can enter the manhole. Note: Abnormalities such as oil or compound leaking from cable or joints, broken cable sheaths or joint sleeves, hot localized surface temperatures of cables or joints, or joints that are swollen beyond normal tolerance are presumed to lead to or be an indication of an impending fault.

1.4 DO NOT switch or rack energized equipment in or out of switchgear in an underground structure. For the Navy, comply with the NAVFACINST 5100.11 Series as follows:

1.4.1 ALL ACTIVITIES shall secure, whenever feasible, all electrical power prior to start of work in electrical vaults, manholes and other confined or enclosed spaces.

2. GENERAL PROTECTION REQUIREMENTS.

2.1 PROTECT pedestrians, motorists, facility workers, and equipment by the use of barriers, warning signs, lights, flags, traffic cones, high-level standards, barricade rope, and flagmen, as appropriate for the job site. Use the guidance from the current Manual on Uniform Traffic Control Devices (MUTCD) to maintain worker safety within a temporary traffic control zone.

2.2 PROTECT approaches to work areas, excavations, open manholes, and parked equipment.

2.3 ENSURE a fully charged and operable handheld fire extinguisher is immediately accessible when performing underground work. Confirm the fire extinguisher is rated for use on electrical equipment.

2.4 MARK ALL EQUIPMENT and materials with red flags by day and red lights by night when located or stored where pedestrians or vehicular traffic might be endangered.

2.5 AVOID parking tool carts and reels on inclined streets. Where this cannot be avoided, equipment must be placed at a slight angle to the curb so that the curb serves as a chock. Chock all wheels with blocks or other suitable items, and install a well-fastened upright brace at both the front and rear of the vehicle. Where more than one reel is parked at the same location, lag the reels together. Place and fasten chock blocks and braces so that they cannot be easily dislodged.

2.6 STORE EQUIPMENT or materials where they do not obstruct fire alarm boxes, hydrants, or fire apparatus.

2.7 COVER OPEN HOLES along streets, driveways, walkways, and accessible places by appropriate strength covers.

2.8 THE FOLLOWING APPLIES to excavation, trenching, and backfilling.

2.8.1 ENSURE all areas are appropriately scoped and marked showing where the exact location of existing electrical, steam, natural gas, water, and cable lines are located prior to any hand (manual) or mechanical digging. Obtain digging permits as required.

2.8.1 USE DITCHING MACHINES with suitable walkways, footboards, and railings, and having protective guards over gears, chains, and other moving parts. Do not stand near digging buckets while the machine is in operation.

2.8.2 WHERE POSSIBLE, excavate trenches in increments to minimize the length of open trenches. On a daily basis, remove spoil to an area where it does not constitute a safety hazard.

2.8.3 KEEP TOOLS, stones, and dirt away from the edges of a trench. In excavations in which workers may be required to enter, excavated and other material must be kept at least 2 ft (0.6 m) from the edge of the excavation.

2.8.4 EXCAVATED MATERIAL REMOVED from trenches in streets must be kept on the traffic side of trenches until used for fill or removed. This will help vehicular traffic avoid the trench.

2.8.5 WHEN WORKERS ARE REQUIRED to be in trenches 4 ft (1.2 m) deep or more, at least two separate and adequate means of exit, such as ladders or steps, must be provided and located to require no more than 25 ft (7.6 m) of lateral travel.

2.8.6 SIDES OF TRENCHES 5 ft (1.5 m) or more in depth must be shored, sloped, or otherwise supported to prevent collapse.

2.9 CAREFULLY refill excavations and see that all refilling is well tamped.

3. CABLE PULLING.

3.1 DO NOT handle pull-wires or pulling-lines within reaching distance of blocks, sheaves, winch drums, and take-up reels.

3.2 DO NOT remain in a manhole during pulling operations.

3.3 DO NOT use wire rope to pull cable in a duct already occupied by conductors.

3.4 USE a nonmetallic duct fishing wire or device when fishing ducts containing energized conductors.

3.5 ALWAYS FISH ducts in the direction that presents the least hazard. Consider stationing a worker at each end when fishing ducts.

4. BURIED ELECTRICAL CABLES.

4.1 USE AREA UTILITY MAPS to locate existing buried cables and nearby utilities as accurately as possible. Locate/scope for buried cables along any intended digging areas. Obtain digging permits, as required.

4.2 USE EXTREME CARE when excavating near or exposing direct-burial electric underground cables. If the depth of all direct-burial cables is definitely known, power digging equipment can be used for excavating all but the last 12 in (305 mm) of cover over the cables. The remaining cover must be removed by use of hand-digging tools with FRP handles. Where the depth of direct-burial cables is not established, power-digging equipment must not be used, except to break and remove the surface pavement.

4.3 DO NOT use probe rods or bars to locate any underground direct-burial cables.

4.4 TAKE EXTREME CARE to avoid damaging the cable insulation when uncovering direct-burial cables.

4.5 PROTECT all exposed cables against damage in a work area with boards or other nonconductive materials. Utilize suitable nonflammable protective material when it is necessary to weld adjacent to cables.

4.6 DO NOT stand, sit, kneel, or lean on unprotected direct-burial cables.

5. DAMAGE TO EXISTING UTILITY LINES. If any existing utility lines are damaged then certain steps must be taken dependent upon the type of line.

5.1 IF ELECTRIC CABLES are damaged the cables must be deenergized and repaired.

5.2 IF HIGH-ENERGY LINES such as natural gas, steam, or hot water are damaged, notify the local fire department, utility office, and security or police department immediately. Shut off all sources of the utility, if possible leave the hole open until all utility line flow has been dissipated safely. Warn and evacuate any workers or residents in the area as necessary, and keep the public well clear of the area.

5.3 ENVIRONMENTALLY SENSITIVE LINES, such as sewer, fuel, and oil, must be handled in accordance with applicable health and safety requirements. Notify the local fire department, utility office, environmental office, and security or police department immediately. Take measures to prevent flow into storm drains or nearby waterways. Cleanup must be initiated as soon as possible.

5.4 OTHER LINES, such as communication, water, and storm drainage, must be handled by notification as soon as possible to the appropriate utility office or maintenance department. Notify the local fire department in case of damage to waterlines since this may impact fire protection systems in the area.

6. PREPARING TO WORK UNDERGROUND.

6.1 GENERAL ATMOSPHERE CONTROL PRECAUTIONS BEFORE ENTRY.

6.1.1 WORK IN UNDERGROUND STRUCTURES must conform to confined space entry permit requirements. Table 1 summarizes the major steps in determining that structures can be safely entered.

1. Secure the work area.
2. Use the probes of an atmospheric tester to check air. First check for moisture on the end of the probe. If none found, test for air. \3\
3. If the atmosphere is within prescribed limits, remove manhole cover.
4. Inspect the structure interior for the presence of water, oil, gasoline, or other contaminants that must be removed before work can proceed. Check the structure by lowering the probe as far as possible.
5. If the atmosphere is within prescribed limits, set up the lifting tripod on the manhole.
6. Enter (and leave) the structure by means of a ladder or climbing device for structures more than 4 ft (1.2 m) deep. Never climb in or out by stepping on cables or their supports.
7. Test the atmosphere at each corner of the structure and at each of the duct entrances. If the atmosphere is still found to be within prescribed limits, work in the structure may commence.
8. Provide additional ventilation as necessary. Continuous monitoring of atmosphere quality should be performed for work taking longer than 15 minutes. \2\ Whenever the cover has been replaced and entry is again required, repeat atmosphere testing. /2//3/
9. Lower tools using a handline. Use the tripod for heavy tools and parts, or when a manhole rescue must be made.

Table 1
Precautions before Entering Underground Structures

6.2 ATMOSPHERE TESTING BEFORE ENTERING UNDERGROUND STRUCTURES.

6.2.1 TEST THE ATMOSPHERE in the underground structure prior to entry to ensure it is safe for workers. Toxic or combustible gases can be present, or there might be a lack

of oxygen in underground structures. No one is permitted in unvented underground vaults, manholes, or other structures unless the atmosphere is found to be safe by testing for both oxygen deficiency and the presence of toxic or explosive gases or fumes.

6.2.2 MANHOLES and other underground structures containing less than 19.5 percent by volume oxygen must not be entered without the use of supplemental breathing air. Entering a manhole or other underground structure with an oxygen deficiency can cause sudden unconsciousness and death by hypoxia (oxygen starvation).

6.2.3 THE FOLLOWING APPLIES to toxic and combustible gases.

6.2.3.1 CONSIDER subsurface structures hazardous until tested clear. They are subject to the accumulation of combustible or toxic gases.

6.2.3.2 COMBUSTIBLE GASES found in manholes or vaults are usually natural gas or vapors from hydrocarbon fuels.

6.2.3.3 TOXIC GASES typically encountered are hydrogen sulfide, carbon monoxide, and mangrove gas (southern coastal areas).

6.3 ATMOSPHERIC TEST EQUIPMENT.

6.3.1 TEST THE MANHOLE or other underground structure with an approved tester prior to entry. Determine that the test instrument is in proper working order and correctly calibrated. Make tests as soon as the manhole cover is removed.

6.3.2 PERFORM OXYGEN DEFICIENCY TESTS with an oxygen deficiency indicator. Operate the indicator instrument in accordance with the manufacturer's instructions.

6.3.3 DO NOT RELY ON YOUR SENSE OF SMELL. Use an approved portable unit to measure the amount of combustible and toxic gases in the manhole atmosphere.

6.3.4 NEVER ENTER A MANHOLE until test results indicate that it is safe for entry.

6.3.4.1 IF TESTS MADE upon removing the manhole cover indicate that the atmosphere is satisfactory, the manhole or vault can be entered and worked in. Additional tests must be made when each crew begins work. The test interval must not exceed 8 hours. When the manhole is covered with a tent or tarpaulin, the test interval must not exceed 2 hours. Place the tent or tarpaulin so that an opening is left in the covering for ventilation. When conditions allow, continuous monitoring is the preferred means of atmospheric monitoring.

6.3.4.2 IF TESTS MADE upon removing the manhole cover indicate that the atmosphere is unsatisfactory, ventilate the manhole or vault with a power blower for a minimum of 10 minutes if more than the allowable trace of gas is found on the initial test, then make a second test with the blower running. If the test is satisfactory, the manhole or vault may be entered. Make this test away from the direct blast of the blower. If gas is again found on the second test, continue to ventilate the manhole with a power blower until the test is satisfactory. Work can then be started in the manhole, provided adequate power blower ventilation is continued. There must be enough ventilation to hold the quantity of gas in the manhole to within an allowable value until the work has been completed and the cover replaced. While working in a manhole being ventilated with a power blower because of previous gas detection, test the atmosphere every hour. If the blower stops, leave the manhole at once and do not re-enter until ventilation has been restored and the atmosphere test is satisfactory. Operate the blower outside of a manhole tent or tarpaulin downwind of the manhole.

6.4 STRAY ELECTRICAL VOLTAGE TESTING. From outside the manhole, use a non-contact audio and visual voltage detector attached to a live line tool to detect for stray

voltages (electric field)/ground leakage currents. If stray voltage is detected, there may be a cable with a bad shield. Try and determine the source of the stray voltage. If the faulty cable cannot be found with the voltage detector, use an infra-red camera (gun) to try and find cable hot spots (if possible). If possible, look for damaged cable with mirrors on a live line tool to try and locate the faulty cable. If the faulty cable is located, deenergize this cable. If the faulty cable cannot be located, all the cables in the manhole must be deenergized until the faulty cable is repaired or remains deenergized.

6.5 PUMPING A MANHOLE. If manhole contains water and needs to be pumped, water must not be allowed to enter storm drains, canals or waterways unless approved by local, state, and federal laws. Water is permitted to be pumped into containers and transported to an approved dumping area. If local policy permits, water may be placed back into the manhole. After a manhole has been pumped, the removal of the water may permit gas to flow into the manhole. Make the test at any open ducts. If a test indicates that gas is entering, ventilate the manhole.

6.6 REMOVAL OF DUCT PLUGS. Immediately upon the removal of the duct plugs, make a test at the opened duct. If gas is entering, ventilate the manhole.

6.7 EMERGENCY ENTRANCE. Use an approved positive pressure respirator or self-contained breathing apparatus, and a safety harness attached to a retrieval device attended by another worker stationed at the opening if it becomes necessary, to enter a manhole or vault where a hazardous atmosphere is present.

6.8 VENTILATION OF UNDERGROUND STRUCTURES. There are three methods that can be used to ventilate a structure. These are the forced air, sail, and natural methods.

6.8.1 FORCED AIR. The forced air method consists of a power blower, blowing air into the manhole. The blower hose is placed into the manhole, forcing fresh air to circulate and oxygen-deficient air to be forced out. This is the best method of ventilating a manhole.

6.8.2 SAIL METHOD. The sail method (refer to Figure 1) ventilates the manhole by using the wind. A piece of plywood or some other material is placed over the manhole. The edge of the plywood facing the wind is lifted up until the plywood forms about a 45-degree angle with the manhole opening. The wind enters the manhole, forcing possible contaminated air out of the manhole.

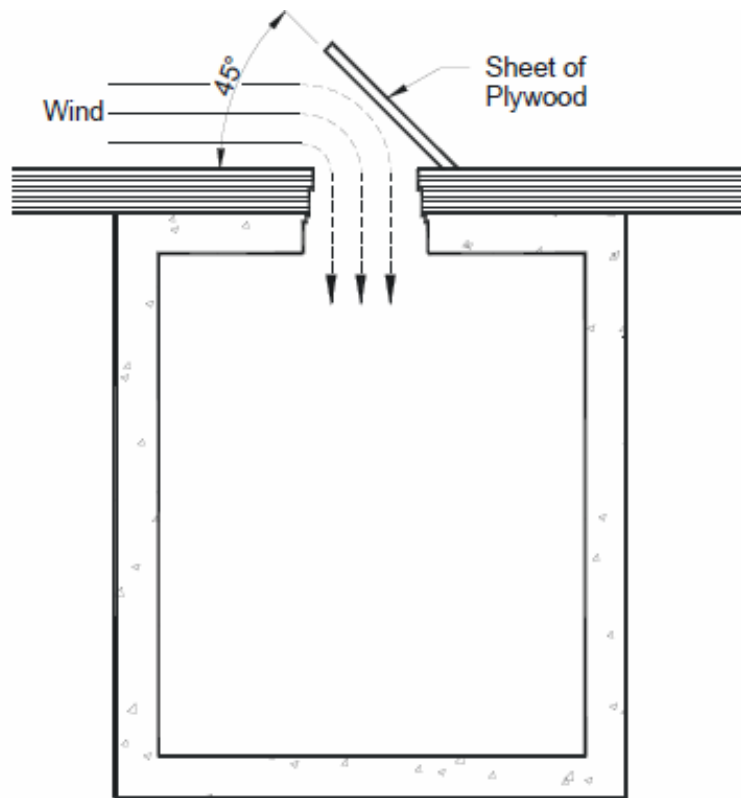

Figure 1

Sail Method of Manhole Ventilation

6.8.3 NATURAL METHOD. This method consists of taking the manhole cover off and letting the internal air escape as much as it can. This method of venting a manhole is the least effective because a gas heavier than air could remain in the bottom of the manhole. Use this method of venting a manhole only as an emergency measure, and only when determined safe.

7. WORK INSIDE UNDERGROUND STRUCTURES.

7.1 GENERAL.

CAUTION

Visually inspect for hazardous conditions such as burnt or cut cables, or loose or defective ladders before starting work. Any signs of cable damage will require the affected cables to be placed in an electrically safe work condition before starting work.

7.1.1 USE A LADDER when entering or leaving a manhole or vault. Climbing into or out of manholes or vaults by stepping on cables or cable supports is prohibited. Use of portable ladders is preferred. Ladders in manholes, if provided, may have rusted and become unsafe.

7.1.2 HANDLE TOOLS in a manner that protects the workers and work area.

7.1.2.1 PLACE TOOLS or materials a safe distance from manhole openings, where they must not cause a stumbling hazard or come in contact with energized conductors or equipment.

7.1.2.2 DO NOT THROW tools or materials into or out of manholes. Use canvas buckets or hand lines for lowering tools or equipment into and removing them from manholes. Warn workers before lowering tools.

7.1.2.3 PROVIDE A SAFETY HARNESS attached to a retrieval device with a windless hand crank for non-entry removal; subsurface worker rescue assembly; or an approved retracting lifeline system.

7.1.3 WHEN THE USE OF open flames is necessary, consider the proximity of combustible or flammable liquids, such as a nearby gasoline service station or

underground fuel storage tank. If in doubt, retest the atmosphere before lighting the open flame. Provide adequate ventilation when open flames are used in manholes.

7.1.4 LOW-VOLTAGE (less than 600 V) equipment can be especially hazardous in or around subsurface structures. Tool frames and cases can become energized by electrical conductors with frayed or damaged insulation. These faults may occur only momentarily or could be prolonged through high-resistance grounding paths. Contact with these energized tool frames and cases in the vicinity of damp, well-grounded floors and walls can easily result in electrocution. Use only approved (ground fault protected, battery operated, or pneumatic) lighting systems and tools in maintaining subsurface structures.

7.1.5. CHECK FOR hazardous/dangerous animals such as snakes or spiders prior to starting work.

7.2 WORK PRECAUTIONS.

7.2.1 PROPERLY IDENTIFY cables before beginning any work. Check cable tags. If tags have become illegible or lost, obtain specific instructions from the authorized individual-in-charge before starting work. Complete re-tagging before starting work.

7.2.2 THE EXTERNAL APPEARANCE of high-voltage and low-voltage cables can be similar. Report any errors found in the cable tags or in the manhole records or maps to the authorized individual-in-charge. Work must not continue until permission is given by the authorized individual-in-charge.

7.2.3 DO NOT remove or place an identification tag on a circuit without direct permission from the authorized individual.

7.2.4 ALL EQUIPMENT INSIDE A MANHOLE operating at high voltage levels, including insulated conductors, should be deenergized before allowing entry into the manhole.

7.2.5 CONSIDER CABLE AND APPARATUS ENERGIZED, and use personal protective equipment until the following steps have been taken.

- Test the item with an approved device and confirm it is deenergized.
- Ground the item from all possible sources of power (including transformer secondary back feed).
- Grounds are provided at the work location. Grounds may be omitted or removed for test purposes with the approval of the authorized individual-in-charge after the circuit has been tested and proven to be deenergized. Omission of grounds must be permitted only if their application would increase the work hazard.
- The cable has been grounded for a sufficient length of time to drain off any static charges.

7.2.6 VERIFY LOW-VOLTAGE CABLES are de-energized and tested with an approved voltage detector.

7.2.7 VERIFY high-voltage cables are deenergized as follows.

7.2.7.1 USE AN APPROVED test device to confirm high-voltage equipment and cables are deenergized when the cable terminals or apparatus are equipped with capacitive test points or have bare exposed parts.

7.2.7.2 IF AN APPROVED test device cannot be used, confirm the equipment and cables are deenergized as follows.

- Isolate the equipment or cable from all possible sources of power, and trace it to the work location.
- Ground the equipment or cable at the work location. Use remote hydraulic grounding spike to ground and drain a cable after it has been deenergized and

before contact is made by hand. The worker must be outside the manhole to operate the remote hydraulic grounding spike.

7.3 WORKING ON CABLES AND APPARATUS. Perform the following when working on cables and apparatus.

7.3.1 MAINTAIN the required minimum approach distance.

7.3.2 ALL CABLE AND APPARATUS must be tagged properly.

7.3.3 PLACE RUBBER BLANKETS or other suitable insulating barriers to prevent accidental contact when a worker is in proximity to live parts.

CAUTION

Blast blankets are prohibited inside manholes. These types of blankets are commercially available, but are not appropriate for use inside a confined space such as a manhole.

7.3.4 CONSIDER the following special hazards.

7.3.4.1 CHECK THE primary and secondary voltage of any transformer fed from a deenergized feeder cable. Ground the cable on each side of the work location.

7.3.4.2 DO NOT open neutral conductors without the prior installation of suitable bypass conductors.

7.3.4.3 NO ENERGIZED CABLE will be moved.

7.3.4.4 DEENERGIZE the circuit before separating or connecting a 600 amp dead-break type separable connector. Verify the circuit is dead by using the associated capacitive test point and an approved test device. Utilize suitable live-line tools in separating or

connecting these separable connectors, unless the circuit has been verified as deenergized and is grounded.

7.3.4.5 BEFORE OPERATING A PRIMARY GROUNDING switch, the authorized operator must be certain of the following.

- All personnel are at their correct location.
- The tags on the feeder cable and equipment in the vault or manhole bear the same numbers as shown on single line drawings.
- Network protectors are in the open position or, in the case of radial transformers, the secondary fuses have been removed and transformer secondaries are deenergized.

7.3.5 ALL CABLE TO BE CUT or repaired shall be positively identified and deenergized before each cut. Before making an opening in or removing a part of the sheath or sleeve of a cable, the line will be grounded at the first possible grounding point on each side of the work location.

7.3.5.1 PERFORM ALL HIGH VOLTAGE CABLE CUTTING remotely from topside using a guillotine cutter and permit no workers to remain in the space during the cutting. This will isolate workers by a safe distance in the event of an accidental arc flash, arc-blast when the cut is made.

7.3.5.2 WHEN CUTTING or opening splices on low-voltage cables, determine whether the cable is energized. Use a non-contact voltage tester. Cut only one conductor at a time on multiple-conductor cables, and make complete tests on at least two conductors before proceeding with the work.

8. LOW-VOLTAGE INTERIOR SYSTEMS

8.1 WORKING ON INDOOR EQUIPMENT.

8.1.1 RESTRICTED SPACE. Be alert that older installations might not meet current NEC clearance and entrance requirements for electrical rooms. Where installations do not conform to current NEC/OSHA requirements, additional safety precautions and instruction must be provided to maintenance workers. Give special attention to the guarding of live parts where current NEC clearances are not met. Ensure that unobstructed emergency exit routes are provided.

8.1.2 GROUNDING SYSTEMS. Verify that existing permanent electrical system grounds are adequate for personnel protective grounding, and provide additional temporary grounding as necessary.

8.1.3 DISCONNECTION OF POWER SOURCES. Be sure to check single line diagrams and verify that all inputs and interconnections to any electric power source are locked and tagged open. Verify single line diagram connections with the actual line connections of the applicable equipment.

8.1.4 RELATED BUILDING SYSTEMS. Do not disable or work on any fire protection and fire alarm systems without prior notification and approval of the local fire department. If the room's ventilation system is affected by the work, ensure that adequate temporary ventilation is provided.

8.2 LOW-VOLTAGE SYSTEMS.

8.2.1 OVERVIEW.

8.2.1.1 COMPLETE any work with only qualified electrical workers with training and experience on low-voltage circuits. Electrical workers must be familiar with NEC requirements and must have work experience with low-voltage systems. Inform the foreman when installations do not meet the requirements of applicable codes and standards, such as the NEC. Electrical workers must understand electrical safety requirements for low-voltage systems.

8.2.1.2 CONSULT the manufacturer's instruction manual if available for the apparatus before starting work.

8.2.1.3 UNLESS SPECIFICALLY APPROVED, work is not permitted on energized circuits. Use temporary ground wires to drain off induced voltages and currents from live circuits, stored energy devices, and equipment metal guards before starting work.

8.2.1.4 IN MANY CASES, contract personnel or specially trained workers will repair complex controls and special equipment.

8.2.2 BATTERY ROOM HAZARDS. The battery safety rules apply to low-voltage systems.

8.2.3 FIRE ALARM SYSTEMS. Maintaining fire alarm systems with their appropriate safety requirements requires special training. Workers must have completed one or more of the following certifications or specialized training.

- Factory trained and certified, or
- Certified by the National Institute for Certification in Engineering Technologies (Fire Alarm Systems), or
- Certified by the International Municipal Signaling Association (Fire Alarm Systems), or
- Certified by state or local authority, or

- Trained and qualified by an organization listed by a nationally recognized testing laboratory for the servicing of fire alarm systems.

8.2.4 SOLID-STATE EQUIPMENT. Adjustable-speed motor controllers, frequency converters, and uninterruptible power supply (UPS) equipment are complex solid-state devices that must generally be maintained by manufacturers or specially trained contract personnel. Facility personnel are not normally trained for such work. Even after initial training, maintenance work is usually done on such an infrequent basis that workers must not be considered qualified. Facilities with these installations must contain cautionary labeling to warn workers of the electric shock dangers involved in operating and maintaining these types of equipment.

8.2.5 LOW-VOLTAGE WORK PRECAUTIONS.

8.2.5.1 ASSUME all parts of an electric circuit are energized until an electrically safe working condition has been established.

8.2.5.2 USE ONLY insulated hand tools when working on equipment where the tool could contact an energized source of 50 V or higher.

CAUTION

Older plastic or rubber coated tools are often not certified by the manufacturer for insulating ability, and the coating is only provided as a comfort feature for the user. If the tool has not been tested, it must be assumed to not meet OSHA requirements for use of insulated hand tools.

8.2.5.3 UNLESS SPECIFIC PERMISSION IS PROVIDED, no work will be performed on energized electrical circuits or equipment operating at more than 50 V phase-to-phase. Follow the safe clearance requirements of Chapter 6. If work is performed on live energized circuits, select the appropriate personal protective equipment in accordance with the criteria provided ELSEWHERE.

8.2.5.4 WHEN WORKING ON OR NEAR ENERGIZED CIRCUITS, workers must stand on a dry surface.

8.2.5.5 IF USING FISH tape near energized parts, cover live parts with rubber equipment.

8.2.5.6 IF WORKING NEAR RUNNING machinery, use extreme care and provide barricades, if necessary.

8.2.5.7 PLACE ALL TOOLS clear of machinery before starting machinery. Never use a wrench on running machinery.

8.2.5.8 PROVIDE adequate illumination.

8.2.5.9 WEAR SAFETY GOGGLES when soldering joints or tinning lugs on connectors.

8.2.5.10 REMOVE TRIPPING HAZARDS before starting work and do not work on slippery surfaces.

8.2.5.11 TAPE OR COVER bare or exposed places on one energized conductor before exposing another energized conductor. Never leave joints or loose ends of wire untapped or otherwise unprotected.

8.2.5.12 AN OPEN KNIFE SWITCH can be hazardous because of the exposure to live parts and because of the arc formed when the switch is opened. Only use knife switches that are enclosed in grounded metal cabinets having the control lever operable from outside the cabinet. Install a knife switch so that the blades are deenergized when the switch is open and oriented so that gravity will not tend to close the switch.

8.2.5.13 PROVIDE FUSES AND CIRCUIT BREAKERS in accordance with the NEC, properly sized to protect the downstream conductors and equipment. Substitution of

conductors for fuses is not permitted. Remove fuses only after opening the upstream disconnect device. Use an insulated fuse puller. Use an insulated fuse puller and PPE.

8.2.5.14 USE PROPERLY GROUNDED portable electric tools, particularly in damp locations or near grounded equipment or piping. Do not open a ground connection to a water pipe or ground rod until the ground wire has been disconnected at the equipment.

8.3 ROTATING MACHINERY.

8.3.1 HAZARDS OF ROTATING MACHINERY. Ensure guards are provided to protect workers from accidental contact with live electrical parts, rotating parts, and hot machine surfaces. Be aware that rotation can loosen grounding connections, hold-down bolts, and fray flexible or cord connections. Be alert to sparking of brushes and insulation failures that may cause flame or molten metal to be ejected from open type motors or generators. Interior electrical work often must be done in close proximity of rotating electrical equipment such as motors and generators. Do not operate rotating machinery without protective guards.

8.3.2 MOTORS AND GENERATORS.

8.3.2.1 AFTER WORK has been performed on circuits to rotating machines, check direction of rotation.

8.3.2.2 ALWAYS TAKE POSITIVE STEPS to ensure that rotating equipment under repair cannot be set into motion.

8.3.2.3 A MEGOHMMETER (megger) can be used to check insulation of motor and generating windings using a current of high voltage and low amperage. Never start a megohm test if there is any external voltage in the test circuit.

8.3.2.4 FOLLOW APPROPRIATE mechanical safety precautions if operating a generator, including:

8.3.2.4.1 ENSURE engine coolant is at the proper level and has the proper amount of antifreeze. Make sure engine lubricant and fuel are at the proper levels. Check hoses for good condition.

8.3.2.4.2 ENSURE engine air requirements for combustion are met. Check air filters and cleaners for cleanliness and good condition.

8.3.2.4.3 VERIFY the engine, generator, and related equipment are clean. Keep oil-soaked rags out of the generating facility to avoid a fire hazard.